

DATASHEET

High-Intensity 100 000cd Aviation Light

ICAO High-Intensity Type B 100 000cd
NVG Compliant Infrared 850nm Light

OBELUX
AVIATION LIGHTS

Obelux Oy, Kutomotie 6 B, 00380 Helsinki FINLAND | The information in this document is subject to change without notice.

© Obelux Oy 2016

Optical Characteristics

- ▶ 100 000cd Flashing @ Day
- ▶ 20 000cd Flashing @ Twilight
- ▶ 2 000cd Flashing @ Night
- ▶ Infrared 850nm
- ▶ Colour aviation WHITE
- ▶ Horizontal radiation pattern 360°
- ▶ Vertical beam 3°

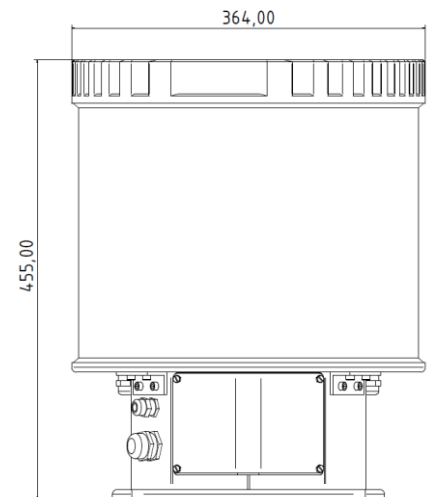

High-Intensity 100 000cd Aviation Obstruction Light

LED Aviation Obstruction Lights

Obelux high-intensity light is designed for marking tall structures such as wind turbines, chimneys, masts, and towers. The product offers unique features such as fault monitoring, photocell and switcher incorporated in the light. Obelux uses a unique environmental friendly optical solution which minimizes light pollution to the neighbourhood.

Specifications met

ICAO International Standards and Recommended Practices:
Aerodromes Annex 14 Volume 1,
6th Edition, July 2013, Chapter 6:
High-intensity Type B.
Fulfils the Recommendations
Section in Table 6-3.

Transport Styrelsen TSFS 2016:95
Luffartstilsynet FOR-2014-07-15-
980

Key Features

- ▶ Based on LED technology
- ▶ 100 000cd WHITE flashing light
- ▶ Photocell and fault monitoring
- ▶ GPS synchronization available
- ▶ NVG compliant infrared 850nm light
- ▶ Both stand-alone and ModBUS operations available
- ▶ More than 20 years of design lifetime
- ▶ Dimmable for 100% / 30% / 10%
- ▶ Hot start for radar controlled systems
- ▶ 5-year warranty

DATASHEET

High-Intensity 100 000cd Aviation Light

ICAO High-Intensity Type B 100 000cd
NVG Compliant Infrared 850nm Light

OBELUX
AVIATION LIGHTS

Obelux Oy, Kutumotie 6 B, 06380 Helsinki FINLAND | The information in this document is subject to change without notice.

© Obelux Oy 2016

Electrical Characteristics

- ▶ Operating voltages 230V_{AC}
- ▶ Constant power input by active PFC
- ▶ Flash rates: 40 fpm
- ▶ Meets standards
 - EMC (Emissions): EN 61000-6-4
 - EMC (Immunity): EN 61000-6-2
- ▶ Power consumption (40 fpm)
 - 200W @ Day
 - 50W @ Twilight
 - 20W @ Night
- ▶ Recommended cables:
 - Power: 3x2,5mm² (Outdoor) L-N-PE
 - Data: CAT 7 (Outdoor)
 - Alarm: CAT 7 (Outdoor)

Mechanical Characteristics

- ▶ Anodised marine grade aluminium body
- ▶ Glass cover
- ▶ Degree of protection IP65
- ▶ Operating temperature range -40...+55 °C
- ▶ Mounting 240x240mm, ϕ 17
- ▶ Height 428 mm, diameter 364 mm
- ▶ Weight 27 kg

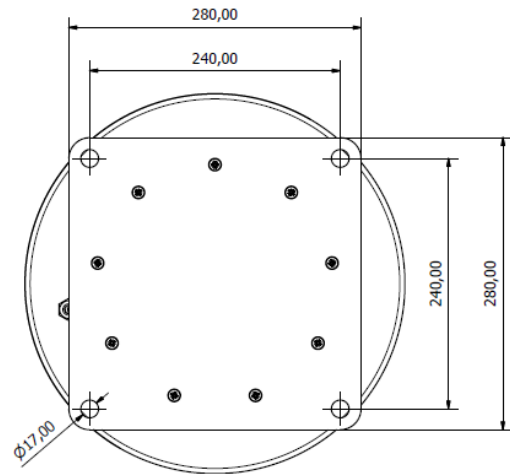

Order code	Output	ICAO	GPS sync	Op. volt.	Infrared	Heating (CCV)	Photocell and Fault monitoring	Packing dimensions
H100IR230I	100 000cd	Type B	No	230VAC	Yes	No	Yes	600x400x400, 32kg
H100IR230GI	100 000cd	Type B	Yes	230VAC	Yes	No	Yes	600x400x400, 32kg
H100IRCCV230I	100 000cd	Type B	No	230VAC	Yes	Yes	Yes	600x400x400, 32kg
H100IRCCV230GI	100 000cd	Type B	Yes	230VAC	Yes	Yes	Yes	600x400x400, 32kg
H100IRCCV230GA	100 000cd	Type B	Yes	230VAC	Yes	Yes	Yes	600x400x400, 32kg

I= ModBUS operation with Obelux Control Panel, Local controller, or similar

A= Stand-alone operation (see User Manual for configuration)

DATASHEET

High-Intensity 100 000cd Aviation Light

ICAO High-Intensity Type B 100 000cd
NVG Compliant Infrared 850nm Light

OBELUX
AVIATION LIGHTS

Obelux Oy, Kutumotie 6 B, 06380 Helsinki FINLAND | The information in this document is subject to change without notice.

© Obelux Oy 2016

Installation specifications

- ▶ EMC cable glands M16 and M25
- ▶ Power input
wire diameter 0,5 – 4mm²
- ▶ RS485 data / ALARM input
wire diameter 0,2 – 1,5mm²

Installation instructions

Mount the device to the selected mounting point using quality made fasteners. Level the light using spirit level (bubble level) if the mounting point is not already levelled. Tighten bolts & nuts. Obelux recommends 100 Nm tightening torque for M12 hot-dipped 8.8 bolts with suitable washer between bolt and mounting plate. When the cover door is open, check that there is no inflow of water (incl. hail and snow) into the cabinet.

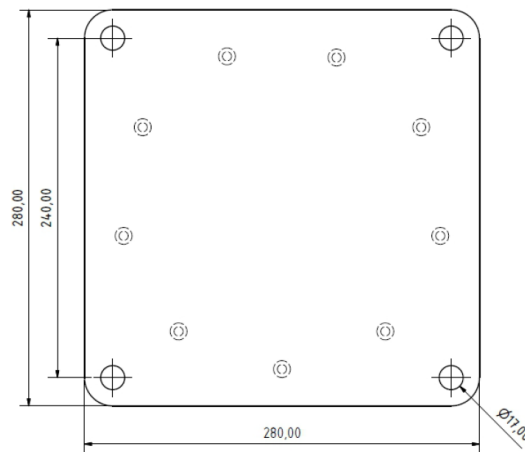

Route power and data cables using cable gland(s). Connect the cable wires securely to appropriate terminal block connectors. Place the hatch plate (door) properly in its place and securely tighten all screws. Make sure that all unused glands or gland holes are sealed.

Follow the illustration below to achieve desired EMC protection.



Please follow these instructions when routing cable via a cable gland:

1. Partially expose the braided screen by removing the outer sheath of the cable at a length of approx. 10 mm.
2. Insert the cable through the dome nut and the gland body until the contact spring is pressed against the braided screen.

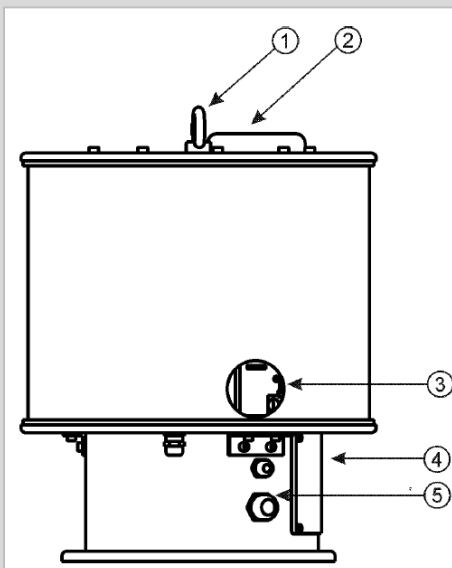

1. Lug (for lifting the light)
2. GPS antenna
3. Location of photocell
4. Service access hatch
5. Cable glands

High-Intensity 100 000cd Aviation Light

ICAO High-Intensity Type B 100 000cd
NVG Compliant Infrared 850nm Light

OBELUX
AVIATION LIGHTS

Obelux Oy, Kutumotie 6 B, 06380 Helsinki FINLAND | The information in this document is subject to change without notice.

© Obelux Oy 2016

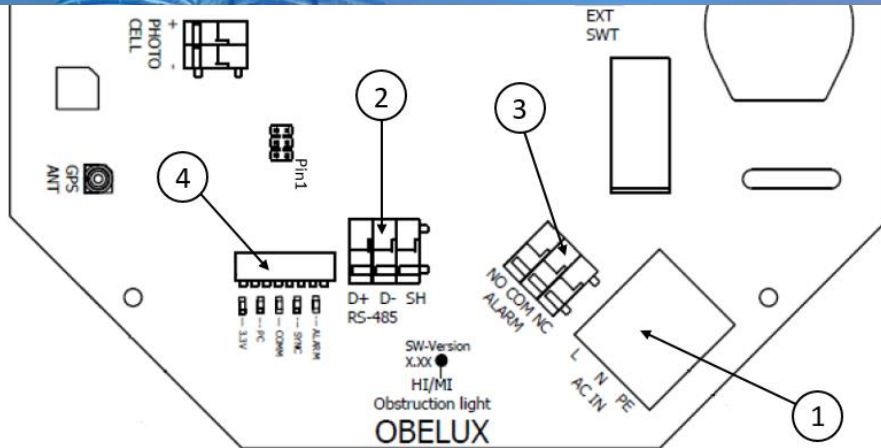

1 Power input

Mark	Description	Information
L	Live terminal	Connect the mains power supply in into these screw connectors.
N	Neutral terminal	Colours are typically brown (for Live) and blue (for Neutral)
PE	Protective earth	Connect protective earth into this screw connector. PE line is typically indicated with yellow/green shield on the wire.

Tighten the connector screws using flat-head (straight) screwdriver.

2 RS485 input

Mark	Description	Information
D+	Data +	RS485 non-inverting pin
D-	Data -	RS485 inverting pin
SH	Shield	Shield

The RS-485 network (bus) input.

3 Alarm Relay Output

Mark	Description	Information
NO	Normally Open	In alarm, connected with COM
COM	Common	Common relay contact
NC	Normally Connected	During normal operations, connected with COM

Unused alarm relay connectors can be left floating i.e. no wiring there is required.

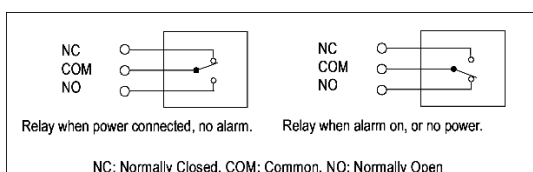

DATASHEET

High-Intensity 100 000cd Aviation Light

ICAO High-Intensity Type B 100 000cd
NVG Compliant Infrared 850nm Light

OBELUX
AVIATION LIGHTS

Obelux Oy, Kutomotte 6 B, 00380 Helsinki FINLAND | The information in this document is subject to change without notice.

© Obelux Oy 2016

4 Configuration DIP switches

Configuration DIP switches are used to configure settings (A=Stand-alone operation) and bus addresses (I=ModBUS operation).

For Stand-alone (A) operation please check separate User Manual for setting configuration.

Configuring Obelux HI Series for ModBUS operation

DIP switches are numbered 1-10, the lowest number (1) being on the leftmost edge of the red/white DIP switch block looked from service access door.

Turn on DIP 8 to configure the light in to Modbus operation. DIP 10 turns on the termination resistor (120Ω) of the light. Termination should be turned on only at the last light head on the bus.

Configuration DIP switches 1-4 are used to give the light RS485 bus address. Duplicate addresses on the same bus are not allowed.

DIP	DIP	DIP	DIP	
1	2	3	4	Modbus Address
on	off	off	off	Address 01
off	on	off	off	Address 02
on	on	off	off	Address 03
off	off	on	off	Address 04
on	off	on	off	Address 05
off	on	on	off	Address 06
on	on	on	off	Address 07
off	off	off	on	Address 08
on	off	off	on	Address 09
off	on	off	on	Address 10
on	on	off	on	Address 11
off	off	on	on	Address 12
on	off	on	on	Address 13
off	on	on	on	Address 14
on	on	on	on	Address 15
off	off	off	off	Address 01